



moby
Designed to Win



Maytronics - Dolphin for every pool



Who is the Moby?

Maytronics is proud to present the Moby - a new Floor Robot, superior to all other alternative Pressure Side and Wheel Driven Cleaners.

With the Moby, Maytronics will be able to fulfill the vision - "A Dolphin for every pool".

What are the main advantages of the Moby over its competitor cleaners?

- Brushing
 - Logic scanning
 - Cleans pool corners - climbs half wall height
 - Lightweight
 - DIY maintenance capabilities - repair by the dealer and end user
 - Fine filtering
 - High filtering capacity
-

What are the technical specifications of the Moby?

- | | |
|-----------------------------|-------------------------|
| • Weight | 8 kg |
| • Height | 22 cm |
| • Cable length | 17 m. |
| • Pumping flow | 16 m ³ /hour |
| • Filter - Bag porosity | 70 micron |
| • Filter - Bag surface area | 0.46 m ² |
| • Water inlet area | 50 cm ² |
| • Floor speed | 10 m/min |
| • Combined brush | Standard |
| • Cycle time | 2.5 hours |
| • Stand | |
| • Power Supply output | 24 volt |
-

What are the commercial specifications of the Moby?

- 2 years warranty
 -
 - Distribution through professional channels only
 - **Availability - Samples - December**
Production - February 2006
 - 28 units on pallet
 - About 720 units in palletized 40 ft. container
-



How does the D.I.Y. (Do It Yourself) after sale service work?

The Moby is designed to be serviced by the dealer and the end user.
The dealer will have spare parts at his level as per group B in the list below.
All other parts will be available at the distributor level. The dealer will be able to order them and repair the Moby by himself.

• ***Spare parts - packed for DIY supply***

Group A - Distributors

Group B - Dealers & end users

Motor Unit
Power Supply
Cable
Side Plate
Outer Casing
Bottom Lid

Impeller
Impeller Cover
Floats
Tracks
Wheel Tubes
Brushes
Filter Bag
Filter Bag Holders

How will dealer Analyze the Moby?

The dealer will get a Tester. The Tester is a "Go/ No Go" tool and will Analyze the Power Supply, Cable and Motor Unit.





How will the dealer or the end user know how to repair the Moby?

An assembly instruction leaflet will be provided.
The assembly procedures will be explained through drawings.

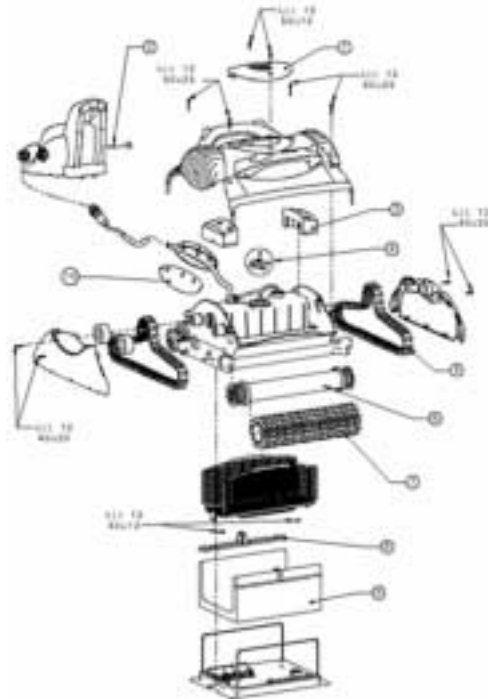

Can the new Dolphin analyzer analyze the Moby?

Yes! At the distributor level the Moby can be fully analyzed by the analyzer.





Positioning!!!

How is the Moby positioned?

The Moby is targeted for the low end pools segment, specifically to compete with the pressure side cleaners. It is aimed to gain additional market share and not to cannibalize the Diagnostic!

Please find below positioning table of the Moby.

Moby versus Pressure Side Cleaner, what are the differences?

	Pressure Side Cleaners	Moby
• Brushes	No - (wheels)	Yes
• Logic scanning	No	Yes
• Climb walls	No	No*
• Filter porosity	200 - 300 micron	70 micron
• Filter surface area	Small	Medium
• Warranty	1 year	2 years
• DIY maintenance	Yes	Yes
• Caddy	No	Stand
• Installation infrastructure	Required	Autonomous

*Climb half wall height to clean pool corner

Moby versus Dolphin Diagnostic, what are the differences?

	Diagnostic	Moby
• Water Line	Yes	No
• Climb walls	Yes	No*
• Filter porosity	50 micron	70 micron
• Filter surface area	Large	Medium
• Warranty	3 year	2 years
• DIY maintenance	No	Yes
• Caddy	Yes	Stand

*Climb half wall height to clean pool corner